

Super SCAR Trigger Installation Instructions

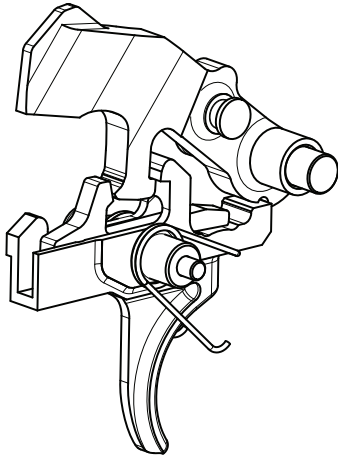

GEISSELE[®]
AUTOMATICS
We Manufacture Confidence[®]

READ THIS FIRST

Firearm safety is **YOUR** responsibility. You must memorize and put into practice the 4 Rules of Firearm Safety:

1. Assume every weapon is loaded.
2. Keep your finger off the trigger until you are ready to shoot.
3. Do not let the muzzle point at anything you are not willing to destroy.
4. Know your target and what is beyond.

The Geissele Automatics Super-SCAR Trigger will lighten the trigger pull relative to a standard trigger. This lightened trigger pull will make the firearm easier to discharge. You must recognize and accept this fact before installing this trigger. If you do not want a lighter than standard trigger pull or are not willing to accept responsibility for the safety of your firearm, yourself, and those around you, do not install this trigger. Geissele Automatics recommends installation only by a certified gunsmith only.

INSTALLATION INSTRUCTIONS

Removal of Stock Trigger

1. Unload weapon and make safe. Remove trigger housing from weapon. Put on safety glasses as you will be working with springs under tension.
2. Remove existing trigger from housing by following the steps below. These steps must be done in sequence.
 - a. Remove small screw on right side safety lever.
 - b. Pry off right side safety lever being careful not to scratch or gouge trigger housing.
 - c. Slide safety out from left side while the hammer is cocked (the

- left safety lever can remain attached to the safety drum). Note that safety detent and spring are now not captured. If the housing is turned upside down they will fall out.
- d. Push left side retaining plate back (in the direction where the safety was). Pull up and remove left retaining plate.
- e. If the weapon is a SCAR 16, push out hammer spring guide pin from left side. This is the big pin above the safety that the hammer spring guide goes through. Do not remove fully, just push through enough so the right side retaining plate can be pivoted upward. Note that the pin is under compression from the hammer spring and it will cock in the housing once one side is released. (The SCAR 17 does not have the right side retaining plate).
- f. Push out hammer pin going from right to left. The hammer is under spring tension. Do not attempt to remove the hammer spring and its guide before this step.
- g. Pull the hammer and hammer spring/guide out of the housing. Remove the spring guide pin.
- h. Push the trigger pin out from right to left. Remove trigger from housing.
- i. Examine the pistol grip screw where it pokes through into the housing floor. The screw must be flush with the floor of the housing. If the screw sticks out into the housing it will interfere with the Geissele trigger. If the screw is not flush, install the supplied shorter pistol grip screw that is enclosed with the trigger.

Installation of Super SCAR Trigger

1. Install trigger and disconnecter assembly making sure that the trigger spring legs are pointing toward the magazine well and are not trapped under the trigger or trapped in the slot for the trigger bow that goes through the bottom floor of the housing. If necessary, push the legs to the side with a small screwdriver.
2. Push the trigger pin in from left to right. This is a tricky step because the pin has two diameters and both have to line up with the receiver wall while also going through the trigger and disconnecter. It helps to pinch the trigger bow in between your fingers and twist the trigger into alignment with the holes. Do not force the pin or use a hammer. Once the trigger is installed, make sure it pivots freely and the trigger spring legs face toward the magazine well.
3. Install the hammer with the hammer spring/guide and spring simultaneously. Note that the hammer will be under force from the hammer spring when pushing the pin in. If the weapon is a SCAR 16, the spring guide pin must be only partially installed. The right side of the pin cannot go through the right side of the housing at this stage of the installation procedure.
4. Once the hammer pin is fully seated, the right retainer plate can be rotated down and the spring guide pin can be inserted through the retainer and then the right wall of the housing. You will have to muscle the guide pin into place as it is under spring tension. The SCAR 17 does not have a right retainer plate so during the hammer installation process the spring guide pin can be fully installed.
5. Cock hammer and preliminarily check for proper trigger operation. Do not let the hammer strike the housing while testing the trigger.
6. Install the left retainer plate and push forward toward the magazine well to seat it.
7. Check for clearance on the sides of the trigger when it comes through the oblong slot in the bottom of the trigger housing. There should be a gap between the trigger and slot about the thickness of 2 sheets of paper. If the gap is not present, relieve the plastic trigger housing with a dremel tool or file. Usually only one side of the slot needs to be relieved. If this relief is not done, trigger operation will be gummy and inconsistent.

GEISSELE® AUTOMATICS

Super SCAR Trigger

8. Install safety and right safety lever. The hammer must be cocked when the safety is installed. The safety detent will need to be pushed down with a small screwdriver that is inserted through the right side safety hole as the safety is installed.

9. Check safety operation: With the hammer cocked and the safety selector in the SAFE position, pulling the trigger hard should not allow the hammer to fall.

10. Check trigger reset: Set selector switch to SEMI. Dry fire weapon and keep trigger held back. Pull charging handle back fully. Let bolt snap forward. Hammer should not fall. Release trigger. Hammer should be caught by trigger.

11. Second stage check: Check for the presence of a second stage by first moving the selector to SEMI. Pull the trigger until you will feel the trigger come to a distinct stop. This is the second stage. Applying additional pressure to the trigger will allow the weapon to discharge.

Maintenance of the Super SCAR Trigger

1. Maintenance of the Geissele Super SCAR trigger consists of occasionally placing a drop of oil on the sides of the disconnecter where

the pin slides through and also on top of the hammer where the pivot nears the housing wall.

2. Apply a small amount of the enclosed grease to the sear surfaces of the hammer and trigger and to the upper and lower faces of the disconnecter where it contacts the tail of the hammer.

3. When the trigger and trigger housing well become very dirty (such as when firing with a suppressor) it is not always necessary to remove the trigger group for cleaning. Flush trigger group with denatured alcohol (or other solvent suitable for the plastic trigger housing) to remove residual oil and dirt. Next, use compressed air to blow off the trigger group and then flush liberally with light lubricating oil such as CLP or CRC3-36. Blow off excess oil with compressed air and apply lubricant as noted above.

Request

The Super SCAR trigger is a new product for Geissele Automatics. It has been tested in four different weapons and I am confident that it will meet your highest expectations. However, whenever any new product is put in service, unanticipated problems or concerns may arise. Be assured that this trigger is covered under the Geissele lifetime warranty which means that as long as I am above ground I will take care of you. I would greatly appreciate an email once you have had an opportunity to shoot your new trigger. Just drop me a few words on how the trigger is working for you and if there is anything you might recommend changing.

Respectfully,
Bill Geissele
whg@geissele.com

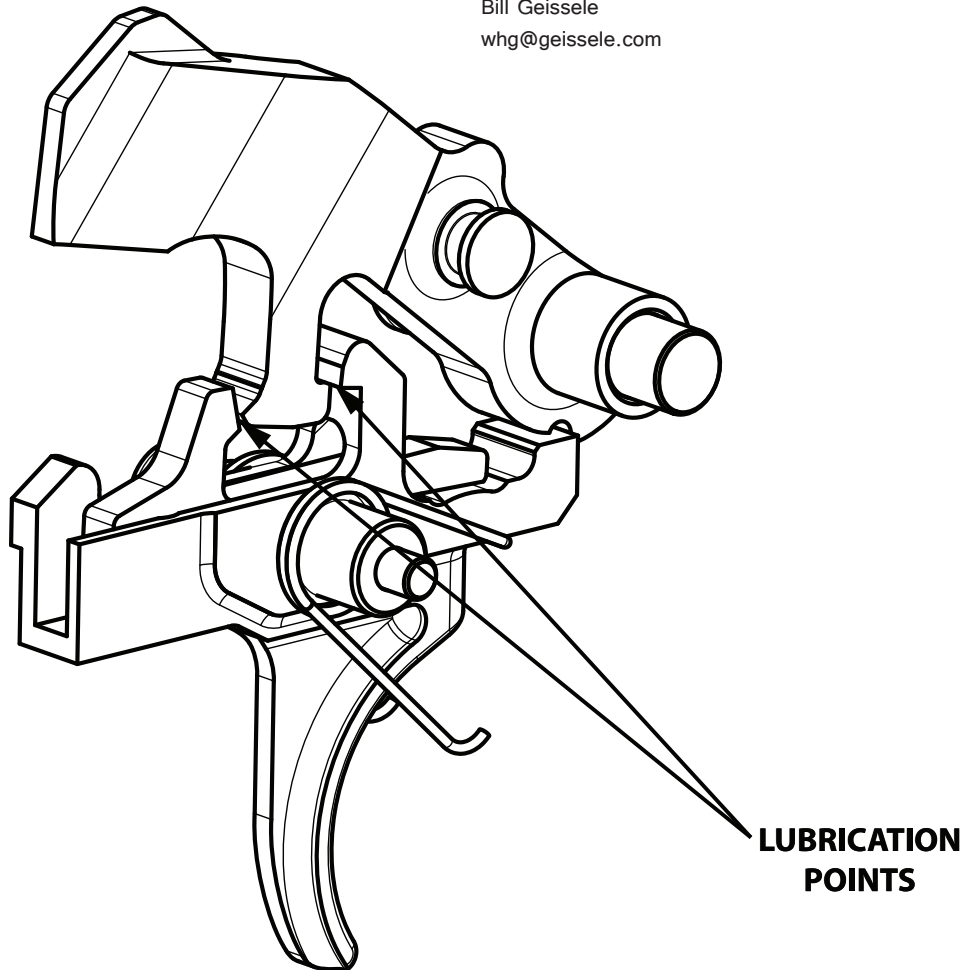

GEISSELE® AUTOMATICS - We Manufacture Confidence®

1920 W. Marshall St. Norristown, PA 19403 | Tel: 610-272-2060 | Fax: 610-272-2069 | www.geissele.com