

GEISSELE[®]

AUTOMATICS

We Manufacture Confidence[®]

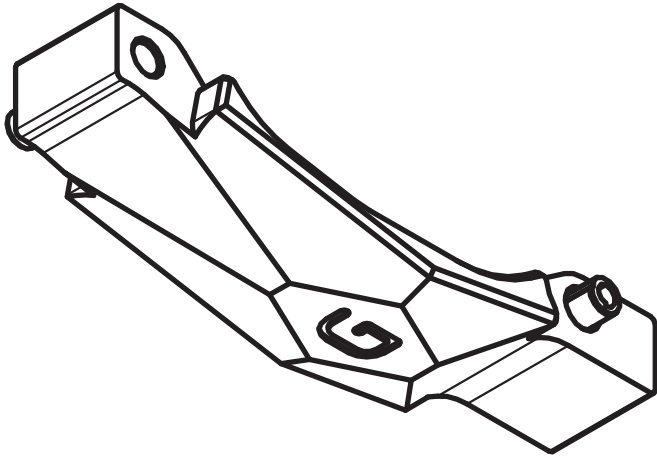

ULTRA PRECISION[™]

5 AXIS TRIGGER GUARD

Installation Instructions

THE GEISSELE ULTRA PRECISION 5 AXIS TRIGGER GUARD COMES PREASSEMBLED TO INSTALL IN YOUR LOWER

1. Insert the trigger guard into the lower as shown in Figure 1. With the holes in the guard and lower lined up lightly tap the roll pin through until flush. A light oil on the hole might assist in the assembly.
2. With the pin inserted move to the front of the trigger guard and locate the 1/16" Hex Key Slot in the specialty screw. This screw should be preassembled in the trigger guard. Loctite has to also be preapplied to this screw.
3. With the screw head lined up with the front hole, turn the screw counter-clockwise to back it out into the hole. Some slight movement may be necessary to make sure the screw lines up properly. Continue to back this screw out until some resistance is felt; then go an additional 10 degrees until snug. The screw is held in with an anti-vibration compound so extreme torque is not necessary. This innovative design leaves the screw fully captured so there is no chance of losing the locating screw when the guard is assembled.

READ THIS FIRST

Firearm safety is **YOUR** responsibility. You must memorize and put into practice the 4 Rules of Firearm Safety:

1. ASSUME EVERY WEAPON IS LOADED.
2. KEEP YOUR FINGER OFF THE TRIGGER UNTIL YOU ARE READY TO SHOOT.
3. DO NOT LET THE MUZZLE POINT AT ANYTHING YOU ARE NOT WILLING TO DESTROY.
4. KNOW YOUR TARGET AND WHAT IS BEYOND.

ASSEMBLY TOOLS:

- 1/16" Hex Key (Included)
- 1/8" Punch
- Appropriate Support Block

INSTALLATION INSTRUCTIONS

Geissele's Ultra Precision[™] 5 Axis Trigger Guard installation is very straightforward however it is in a very vulnerable location on the lower receiver. It is suggested a qualified gunsmith complete the assembly.

The most important tool for the assembly is a good punch block. The tabs on the lower are very fragile and prone to breakage. It is imperative that these tabs are properly supported or permanent damage could result.

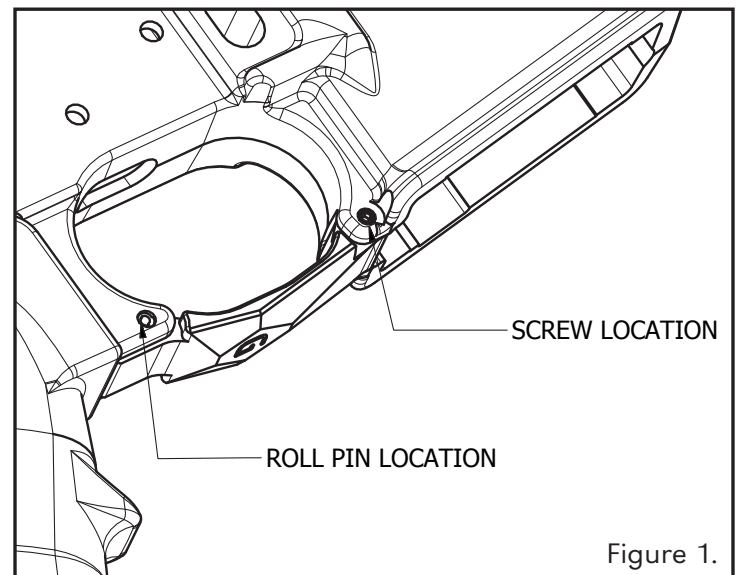

Figure 1.

Thank You For Your Purchase.
Contact Geissele Automatics with any questions.

GEISSELE AUTOMATICS • 800 NORTH WALES RD • NORTH WALES, PA 19454
TEL: 610-272-2060 | FAX: 610-272-2069
E-MAIL: INFO@GEISSELE.COM | WEB: WWW.GEISSELE.COM

GEISSELE AUTOMATICS ULTRA PRECISION TRIGGER GUARD - 02/2020