

GEISSELE BULLETPROOF GUARANTEE
LIMITED LIFETIME WARRANTY

Geissele Automatics warrants its firearms, components, and tools against defects in materials and workmanship during the lifetime of the product. Geissele Automatics does not warrant against normal wear and tear, items consumed or expended by their normal use (including springs, pins, etc.), product misuse (including criminal misuse, negligence or use under the influence of drugs or alcohol), accidental damage, or damage caused by improper handling, unapproved modifications to the product, defective or improper ammunition, or corrosion. Defective accessories (e.g., scopes, suppressors, flash hiders, sights, slings, parts with glass or electronic components, etc.) may be warranted by their original manufacturers but are not covered by this warranty.

UNLESS OTHERWISE REQUIRED BY LAW, IN NO EVENT SHALL GEISSELE AUTOMATICS BE LIABLE FOR PERSONAL INJURY OR PROPERTY DAMAGE, OR ANY INCIDENTAL, PUNITIVE, SPECIAL, INDIRECT OR CONSEQUENTIAL DAMAGES WHATSOEVER, INCLUDING, WITHOUT LIMITATION, DAMAGES FOR LOSS OF PROFITS, LOSS OF DATA, BUSINESS INTERRUPTION OR ANY OTHER COMMERCIAL DAMAGES OR LOSSES, ARISING OUT OF OR RELATED TO YOUR USE OR INABILITY TO USE GEISSELE AUTOMATICS' PRODUCTS, HOWEVER CAUSED, REGARDLESS OF THE THEORY OF LIABILITY (CONTRACT, TORT OR OTHERWISE) AND EVEN IF GEISSELE AUTOMATICS HAS BEEN ADVISED OF THE POSSIBILITY OF SUCH DAMAGES.

THIS LIMITED WARRANTY IS IN LIEU OF AND GEISSELE AUTOMATICS DISCLAIMS ALL OTHER WARRANTIES, EXPRESS OR IMPLIED, INCLUDING BUT NOT LIMITED TO ANY IMPLIED WARRANTIES OF MERCHANTABILITY OR FITNESS FOR A PARTICULAR PURPOSE. TO THE EXTENT ANY IMPLIED WARRANTIES MAY NONETHELESS EXIST BY OPERATION OF LAW, SUCH WARRANTIES ARE LIMITED TO THE DURATION PROVIDED BY LAW.

If you submit a valid claim under this Limited Lifetime Warranty, Geissele Automatics will authorize your return of the product and, at its sole discretion, will (i) repair the product, including replacement of defective parts with new or refurbished parts, or (ii) replace the product with a product of equal or greater value. If Geissele Automatics decides to replace a product under this warranty, Geissele will keep the product being replaced.

You must satisfy all terms and restrictions set forth in this Limited Lifetime Warranty and obtain a Return Material Authorization before shipping any product to Geissele Automatics. Before shipping any product to Geissele Automatics, please ensure that the following: (1) the product has not been modified, is clean and any accessories have been removed (unless otherwise instructed by a Geissele Automatics technical support agent); (2) there is no ammunition in any product or packaging; (3) the completed Return Material Authorization form has been placed inside the packaging; and (4) the Return Material Authorization number has been clearly written on the outside of the packaging. Any failure to follow these instructions could result in your package being refused and returned to you without repairs at your expense.

To obtain service, contact Geissele Automatics at sales@geissele.com or 610-272-2060. This warranty gives you specific legal rights, and you may also have other legal rights which vary from State to State.

Geissele Automatics
800 North Wales Road
North Wales, PA 19454
Phone (610) 272-2060
Fax (610) 272-2069

**SUPER MODULAR RAIL
MK16 MAGPUL M-LOK**

US PATENT D844,094 / D844,094

Parts List		
ITEM	QTY	PART NUMBER DESCRIPTION
1	1	02-974 HANDGUARD
2	1	02-502 BARREL NUT
3	1	02-810 PRESS NUT, M6 X 1.2 HOLE
4	2	02-860 PLUNGER, BOLT RETAINER
5	1	04-283 SPRING, BOLT RETAINER
6	2	02-1013 BOLT, RAIL MOUNTING
7	2	02-323 WASHER, M6 SCREW
8	2	06-102 #8-32 X 5/16 OVAL POINT SHSS

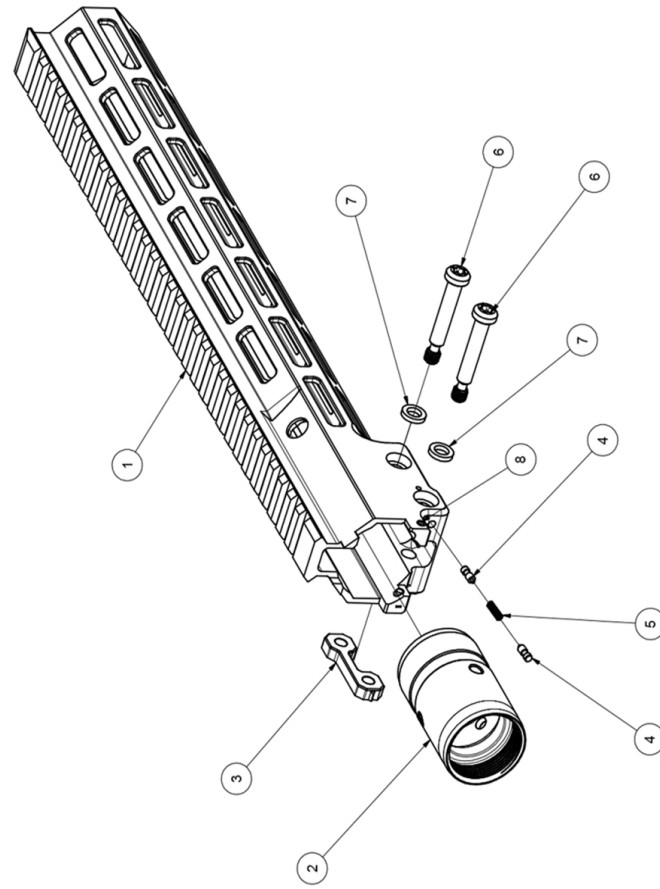

GEISSELE[®]
AUTOMATICS
We Manufacture Confidence[®]

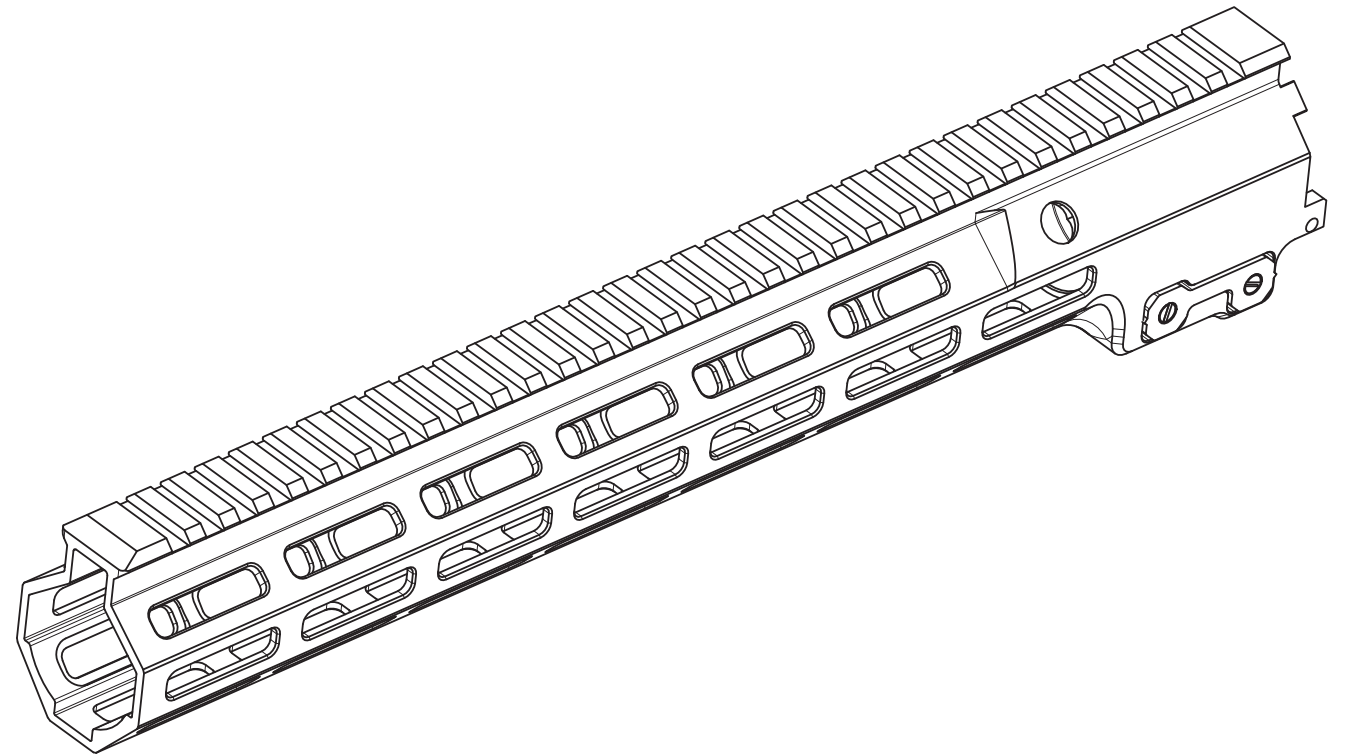

**SUPER MODULAR RAIL
MK16 MAGPUL M-LOK**

INSTALLATION INSTRUCTIONS

GEISSELE AUTOMATICS
800 NORTH WALES ROAD • NORTH WALES, PA19454
610.272.2060 • GEISSELE.COM

GEISSELE[®] AUTOMATICS

We Manufacture Confidence[®]

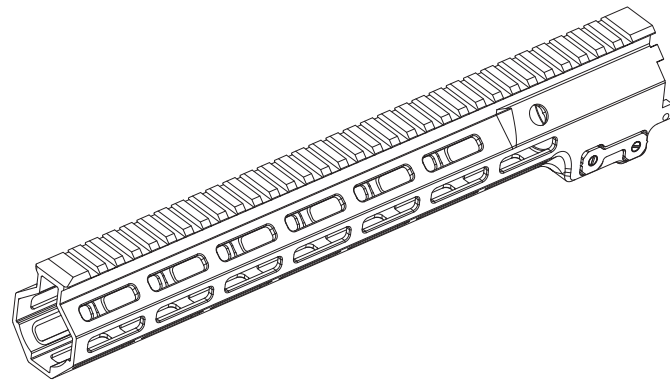

SUPER MODULAR RAIL MK16 M-LOK

Firearm safety is **YOUR** responsibility. You must memorize and put into practice the 4 Rules of Firearm Safety:

- 1. ASSUME EVERY WEAPON IS LOADED.**
- 2. KEEP YOUR FINGER OFF THE TRIGGER UNTIL YOU ARE READY TO SHOOT.**
- 3. DO NOT LET THE MUZZLE POINT AT ANYTHING YOU ARE NOT WILLING TO DESTROY.**
- 4. KNOW YOUR TARGET AND WHAT IS BEYOND.**

A BRIEF DESCRIPTION OF THE MK16 M-LOK

The Super Modular Rail MK16 was developed for today's Infantry Rifleman using Magpul's M-LOK Technology. The SMR MK16 M-LOK is a simple design, which allows required Preventative Maintenance Checks & Services (PMCS) to be performed in an austere operational environment with minimal tools.

The SMR MK16 M-LOK was designed as a lightweight, ergonomic and modular option for the M4 Carbine and M16 family of weapons. Easy on/off capability and fully captive mounting hardware make it an upgrade geared for the Infantryman.

The SMR MK16 M-LOK allows the use of a low profile gas block such as the Geissele Super Gas Block (SGB) to maximize space to mount current and future enhancements.

Superior in rigidity, robust, simple to service and maintain, the SMR MK16 M-LOK can withstand the realities of today's operations and accommodate an increasingly evolving package of shooter enhancements.

Please note that the SMR MK16 M-LOK series does NOT include accessory rails unless otherwise specified.

INSTALLATION INSTRUCTIONS

Refer to SMR MK16 M-LOK drawing on the back for the item numbers and positioning of the rail components.

1. Remove existing flash hider, handguard and front sight/gas block/gas tube (if applicable).
2. Use the Geissele barrel nut wrench (sold separately) to remove the stock barrel nut and discard (if applicable).
3. Remove barrel and inspect and clean the upper receiver threads. Reinstall the barrel being careful to align the barrel extension indexing pin with its corresponding slot in the upper receiver threads.
4. Liberally coat the upper receiver threads and the outer face (torque shoulder) of the barrel extension with anti-seize or grease. If these are not available, oil or CLP may be substituted.
5. Slide the aircraft aluminum Geissele barrel nut (Item 2) over the barrel and hand tighten.
6. Use the Geissele barrel nut wrench to tighten the Geissele barrel nut to 50 ft-lbs by using the pin and corresponding hole in the OD of the barrel nut. Torquing of the barrel nut is recommended. However, for the last 40 years the stock barrel nut has not been torqued, only indexed to line up with the gas tube. If you are an experienced AR builder and are sure of your ability to properly tighten the stock barrel nut you can alternately tighten the Geissele barrel nut with a ratchet or breaker bar in the 1/2" square aperture in the Geissele wrench.
7. Install the gas block and gas tube being careful to line up the gas tube with the center of the gas tube hole in the upper receiver. Once installed take the bolt carrier assembly and slide into the upper receiver making sure the gas tube slides freely onto the gas key and there is no binding.
8. Slide the SMR handguard (Item 1) onto the barrel nut. Be very careful when doing this as the clearance between the OD of the barrel nut and ID of the handguard is precisely machined to about 0.001" clearance. Burrs or dings on the barrel nut will not allow the handguard to slide freely. It is recommended to lightly coat the barrel nut OD and ID of the handguard with a light film of oil before installing until you get the hang of installation. Slide the handguard against the barrel nut, then use your fingers to align the other end of the handguard concentric to the barrel so the rail section is not cocked. By wiggling the handguard very slightly and pressing downward it will start on the barrel nut. Once it is about 1/2" onto the barrel nut it can be slid home. Do not force the handguard onto the barrel nut. If force is needed there is something wrong. Remove the handguard and inspect the OD and ID interface.
9. Install the two rail mounting bolts (Item 6). You may have to slide the handguard slightly to line up the

holes with the grooves in the barrel nut in order for the bolts to start. Start the bolt threads into the press nut (Item 3). Do not tighten the rail mounting bolts fully at this time.

10. Time the top M1913 rail to the M1913 rail on top of the upper receiver so that the rails are rotationally aligned.
11. Using a T30 Torx or star key, tighten the two rail mounting bolts to at least 6.0 ft-lbs, NOT EXCEEDING 8 lbs. Maintain hand pressure on the rail during the tightening process to ensure it does not rotate out of alignment.
12. Tighten the two rounded point set screws (Item 7) against the upper receiver using a 5/64" Hex Key. These two screws are just a secondary method of ensuring the rail section does not rotate. The clamping of the rail onto the barrel nut is very secure and will not rotate even under abuse. Just a light finger tight torque on the screws is all that is needed for a bombproof anti-rotation feature.
13. Be sure to check and retighten the rail mounting bolts after the first firing of the weapon. The dogbone nut has two small barbs that bite into the rail to keep the dogbone nut captured and prevent it from falling out when the mounting bolts are removed. It takes a little time for the barbs to fully seat into the rail; one or two re-tightening's of the mounting bolts are all that is needed to ensure a fully seated dogbone nut.

ATTENTION: Do not tighten the cross bolts when the rail is not installed on a barrel nut. Tightening the bolts with the rail un-installed will crush the ID to the point where the rail is unusable. Tightening the mounting bolts to more than 8 ft-lbs will also damage the rail. If a torque wrench is not available, turn the fastener until hand tight using a long armed Torx key.

UTILIZING THE M-LOK ATTACHMENT SYSTEM

The MK16 M-LOK has been designed using Magpul's advanced M-LOK modular locking accessory mounting system. This system allows the user to easily add or remove accessories based on mission requirements using a 1/8" hex key. Be sure to read the instructions below carefully, improper installation may cause permanent damage to your rail that is not covered by the Geissele warranty.

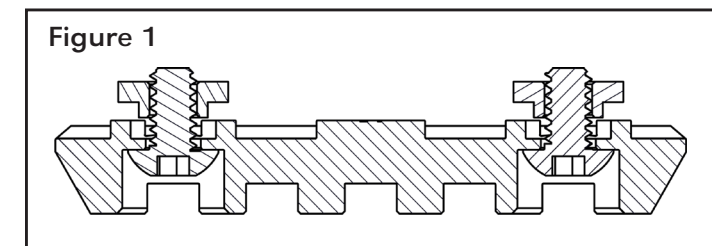

14. To install make sure the nut is started onto the bolt with at least 1 full thread showing out the back of

the nut (Figure 1). If one full thread is not showing, there is a chance that the M-LOK nut will not cam into the M-LOK slot properly. If this occurs and the screw is tightened, the M-LOK nut can pull through the rail leaving a gash in the rail and causing a burr in the surface.

Figure 2

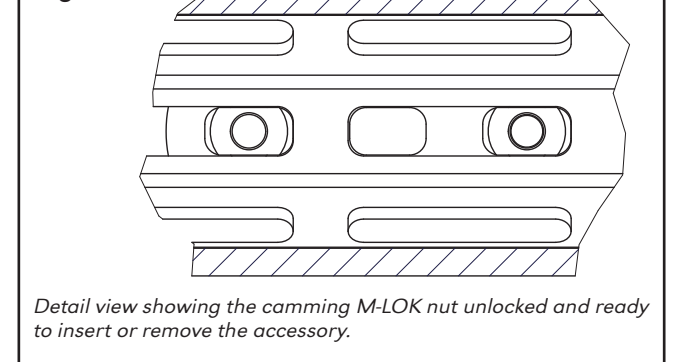

15. Align the nut with the recoil lugs so they pass through the M-LOK slots (Figure 2).

Figure 3

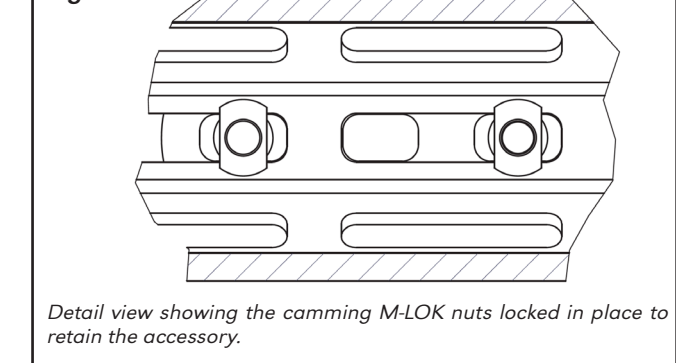

16. Begin to tighten the bolt one full turn with the hex key. The cammed nut will rotate, tighten, and eventually lock into place retaining the accessory on the handguard. Additional torque can be applied to hold the accessory in place (Figure 3).
17. Removing the accessory requires 1 turn counterclockwise. The cammed nut will align with the recoil lugs on the accessory allowing the accessory to come off the rail. Care should be taken to not remove the nut from the bolt or M-LOK accessory. Loosening the screw further than 1 turn may result in permanent damage to the rail.

Thank You For Your Purchase.
Contact Geissele Automatics with any questions.

GEISSELE AUTOMATICS • 800 NORTH WALES RD • NORTH WALES, PA 19454
TEL: 610.272.2060 | FAX: 610.272.2069
E-MAIL: INFO@GEISSELE.COM | WEB: WWW.GEISSELE.COM

SMR MK16 M-LOK Installation Instructions, 07182019